

Hoffman

CALIFORNIA-INTERNATIONAL FABRICS

PALETTE of the Season



Little Firecracker

designed exclusively for Hoffman Fabrics by

Jean Impey

Finished Size: 53" x 53"

FREESHOP-209-Patriotic

Little Firecracker

Fabric Requirements



1895 87-Blueberry
5/8 Yard



1895 301-Bluebird
1 Yard



1895 113-Frost
1/2 Yard



1895 307-Snow
1/2 Yard



1895 231-Garnet
1/2 Yard



1895 348-Lucy
1 1/2 Yards



1895 242-London
5/8 Yard



1895 444-Chilies
1/2 Yard



1895 254-Tahiti
1 3/4 Yards
*includes binding



1895 462-Dewdrop
1 Yard



1895 292-Cardinal
1/2 Yard



1895 492-Breeze
1/2 Yard

Other supplies:

Paper suitable for copying foundation patterns

Template plastic

Small piece of lightweight non-fusible interfacing (woven or unwoven)

Little Firecracker

*Paper piecing knowledge and experience recommended.

Cutting

Note:

All strips are cut across the width of the fabric (perpendicular to selvages) unless noted otherwise. All seams are 1/4". Fabrics are used within the Pineapple Block in a random, scrappy style. There is no specific fabric placement used for the logs except to keep red, white and blue fabrics positioned as shown.

A. Blueberry

Cut several 1 1/2" strips to use for paper piecing. You can cut more as needed.
(Pineapple Block Logs)

B. Frost

Cut several 1 1/2" strips to use for paper piecing. You can cut more as needed.
(Pineapple Block Logs)

C. Garnet

Cut several 1 1/2" strips to use for paper piecing. You can cut more as needed.
(Pineapple Block Logs)

D. London

Cut several 1 1/2" strips to use for paper piecing. You can cut more as needed.
(Pineapple Block Logs)

E. Tahiti

Cut five 1 1/4" strips. Sew strips together end to end with diagonal seams. Press seams open. From pieced strip, cut two 1 1/4" x 44" strips and two 1 1/4" x 45 1/2" strips. (Second Border)

From remainder of 1 1/4" strips, cut four 1 1/4" squares. (Corner Squares/First Border)

Cut six 2 1/2" strips. (Binding)

Cut one 3 3/4" strip; sub-cut eight 3 3/4" squares. Cut each square diagonally in both directions to yield thirty-two quarter-square triangles. (X-Blocks Outer Border)

Cut two 4 1/4" strips; sub-cut four 4 1/4" squares and four 4 1/4" x 8" rectangles and three 3" circles using template. (Dresden Fan Blocks Outer Border)

From remaining fabric, cut several 1 1/2" strips to use for paper piecing. You can cut more as needed. (Pineapple Block Logs)

F. 292-Cardinal

Cut several 1 1/2" strips to use for paper piecing. You can cut more as needed.
(Pineapple Block Logs)

G. 301-Bluebird

Cut three 3 3/4" strips; sub-cut thirty-two 3 3/4" squares. Cut each square diagonally in both directions to yield one hundred twenty-eight quarter-square triangles.
(X-Blocks Outer Border)

From remaining fabric, cut several 1 1/2" strips to use for paper piecing. You can cut more as needed. (Pineapple Block Logs)

H. 307-Snow

Cut several 1 1/2" strips to use for paper piecing. You can cut more as needed.
(Pineapple Block Logs)

I. 348-Lucy

Cut five 1 1/4" strips. Sew strips together end to end with diagonal seams. Press seams open. From pieced strip, cut four 1 1/4" x 42 1/2" strips. (First Border)

Cut one 2 1/2" strip; sub-cut sixteen 2 1/2" squares. (Pineapple Block Centers)

Cut one 3" strip. Use Corner Block blade template to trace & cut twelve blades.
(Corner Dresden Fan Blocks)

Cut one 3 1/4" strip. Use Side Block blade template to trace & cut sixteen blades.
(Side Dresden Fan Blocks)

Cut two 7" strips; sub-cut forty 7" x 2" rectangles. (X-Blocks Outer Border)

From remaining fabric, cut several 1 1/2" strips to use for paper piecing. You can cut more as needed. (Pineapple Block Logs)

J. 444-Chilies

Cut several 1 1/2" strips to use for paper piecing. You can cut more as needed.
(Pineapple Block Logs)

K. 462-Dewdrop

Cut one 3" strip. Use Corner Block blade template to trace & cut twelve blades.
(Corner Dresden Fan Blocks)

Cut four 3" strips; sub-cut eighty 3" x 2" rectangles. (X-Blocks Outer Border)

Cut one 3 1/4" strip. Use Side Block blade template to trace & cut sixteen blades.
(Side Dresden Fan Blocks)

From the balance, cut several 1 1/2" strips to use for paper piecing. (Pineapple Block Logs)

L. 492-Breeze

Cut several 1 1/2" strips to use for paper piecing. You can cut more as needed.
(Pineapple Block Logs)

Interfacing: Use circle template to cut three 3" circles.

Construction

Pineapple Blocks = 10 1/2" finished

1. Make sixteen copies of the foundation pattern that measures 11" unfinished.

* There are 2 printing options:

1. Print (sixteen x 4)-8 1/2" x 11" pages and tape together.
2. Print sixteen 11" x 17" pages. No taping needed. Due to printing restrictions, extend sewn block to 11" unfinished side to side.

2. Sew paper-pieced blocks using 2 1/2" (I) squares for the center of each block. Use 1 1/2" red, white and blue strips for the logs. Refer to diagram to place strips in correct order and positions. Because the blocks have random placement, logs are not precut. Use strips efficiently.

Corner Dresden Fan Blocks = 3 3/4" finished

1. Fold one (I) corner blade in half with right sides together. Sew across the wide end of the blade with a 1/4" seam. Trim the inside point at a slight angle. Finger press seam open or to one side. Turn right side out. Keeping seam centered, press blade. Repeat to make twelve blades.



2. Repeat Step 1 using (K) corner blades.

3. Sew three (I) blades alternately with three (K) blades. Press seams open or toward the red blades. Repeat to make four Corner Dresden Fans.



4. With right side toward interfacing, place one 3" (E) circle with one interfacing circle. Stitch around outer edge with a 1/4" seam. Make a small slit in the interfacing and turn right side out. Work seam to be smooth and press. Fold circle into quarters and crease. Cut on the creases to create four quarter-circles.

5. Pin one Dresden Fan on one 4 1/4" (E) square matching raw edges. Pin one (K) quarter-circle on top of fan matching corner to (E) corner. Appliqué edges of fan to background square using your preferred choice of thread and stitch. Appliqué the center to the fan. Repeat to make four Dresden Fan Corner Blocks.



Block with 1/4 circle – Make 4.

Side Dresden Fan Blocks = 3 3/4" x 7 1/2" finished

1. Make (I) and (K) side blades using the same technique used for Corner Dresden Blocks. Make sixteen of each color blade.
2. Sew four (I) blades alternately with four (K) blades. Press seams open or to one side. Repeat to make four Side Dresden Fans.
3. Use remaining two 3" (E) circles and prepare as noted in Step 4 in the corner blocks. However, cut faced circles in half, not in quarters. You should have four half-circles.
4. Center and pin one fan on one 4 1/4" x 8" (E) rectangle matching raw edges. Center and pin one (K) half-circle on top of fan. Applique as for the corner blocks. Repeat to make four Side Dresden Fan Blocks.



Make 4.

X-Blocks = 3 3/4" finished

1. Make (40) copies of the X-Block foundation patterns that measure 4 1/4" unfinished.
2. Use two 3 3/4" (G) triangles, one 3" x 2" (K) rectangle and one 7" x 2" (I) rectangle to paper piece the first section of one X-Block "A". Use two 3 3/4" (G) triangles and one 3" x 2" (K) rectangle to paper piece the other section of the block. Sew sections together to complete one block. Repeat to make twenty-four "A" blocks.



Make 24.

3. Use two 3 3/4" (G) triangles, one 3" x 2" (K) rectangle and one 7" x 2" (I) rectangle to paper piece the first section of one X-Block "B". Use two 3 3/4" (E) triangles and one 3" x 2" (K) rectangle to paper piece the other section of the block. Sew sections together to complete one block. Repeat to make sixteen "B" blocks.



Make 16.

Assembly

1. Refer to quilt image for correct placement, lay blocks into four rows – four blocks per row. Press seams open or in opposite directions from row to row. Sew rows together and press seams open.
2. Sew one 1 1/4" x 42 1/2" (I) strip to both sides of the quilt center. Press toward the strips. Sew one 1 1/4" (E) square to both ends of remaining 1 1/4" x 42 1/2" (I) strips. Press toward the strips. Sew these pieced strips to the top and bottom of the quilt center. Press toward the strips.
3. Sew one 1 1/4" x 44" (E) strip to both sides of the quilt. Press toward the strips. Sew one 1 1/4" x 45 1/2" (E) strip to the top and bottom of the quilt. Press toward the strips.
4. Referring to quilt image for correct placement, sew six "A" X-Blocks, four "B" X-Blocks and one Side Dresden Fan Block together to create one side border. Press seams open or to one side. Repeat. Sew borders to both sides of the quilt and press.
5. Repeat Step 4 but sew one Corner Dresden Fan Block to both ends of the borders. Sew borders to the top and bottom of the quilt and press.

Finishing

1. Prepare backing fabric and press well.
2. Layer backing, batting and quilt top. Baste and quilt as desired.
3. Trim layers even with quilt top squaring corners.
4. Prepare binding using 2 1/2" (E) strips with diagonal seams. Press seams open and trim. Fold binding in half with wrong sides together and press. Sew binding to quilt using your preferred method.

OR OPTIONAL QUILT BACK IDEA:

Make it a two-sided quilt and a bit of modern too.
Using the beautiful digital fabric **S4831 Bluebird HOFFMAN'S WAVES**, this ombre design was cut into Court House Steps strips. Look for the complete instructions for Maze Craze on the Hoffman website pattern page.



X-Block "A"

3 3/4" finished

4 1/4" with seam allowance

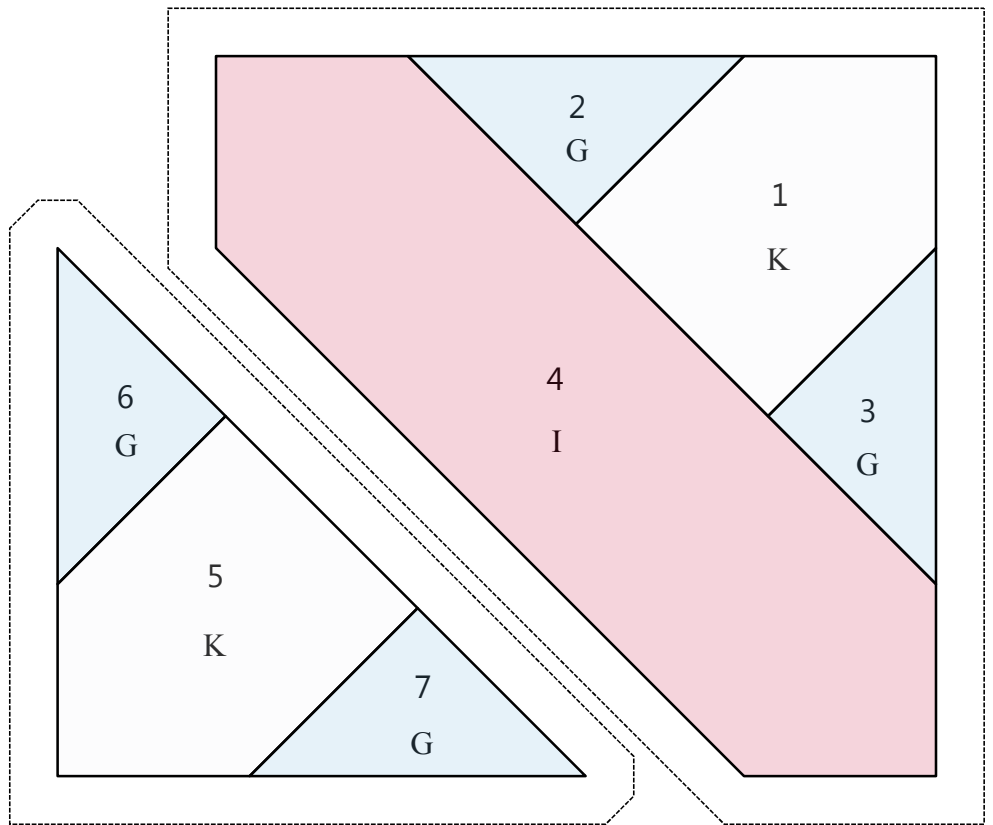

Make 24 copies.

You will need 24 for Block A
and only 16 for Block B.

X-Block "B"

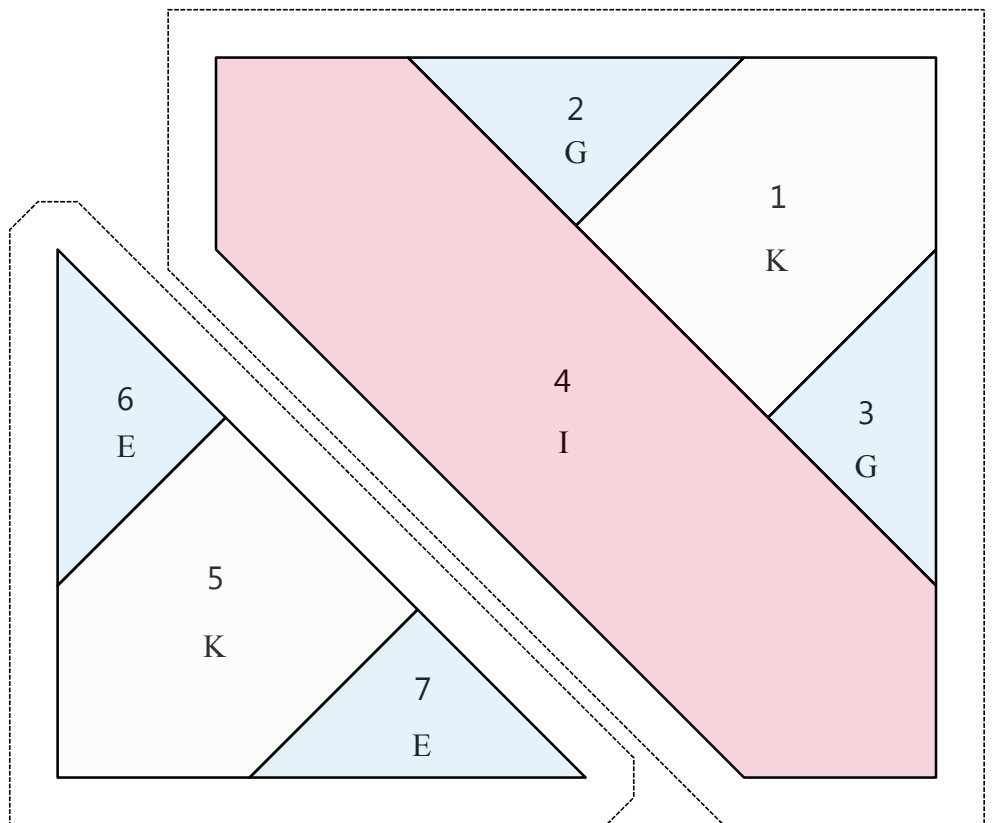

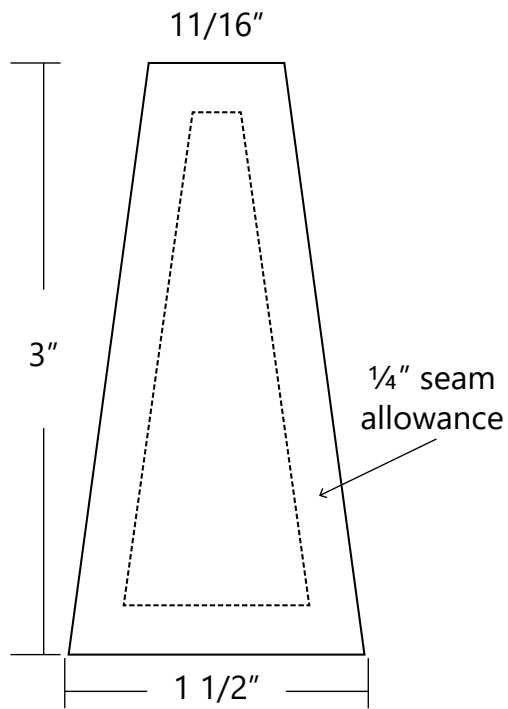

Corner Dresden Fan Template
Cut (12) Fabrics I & K

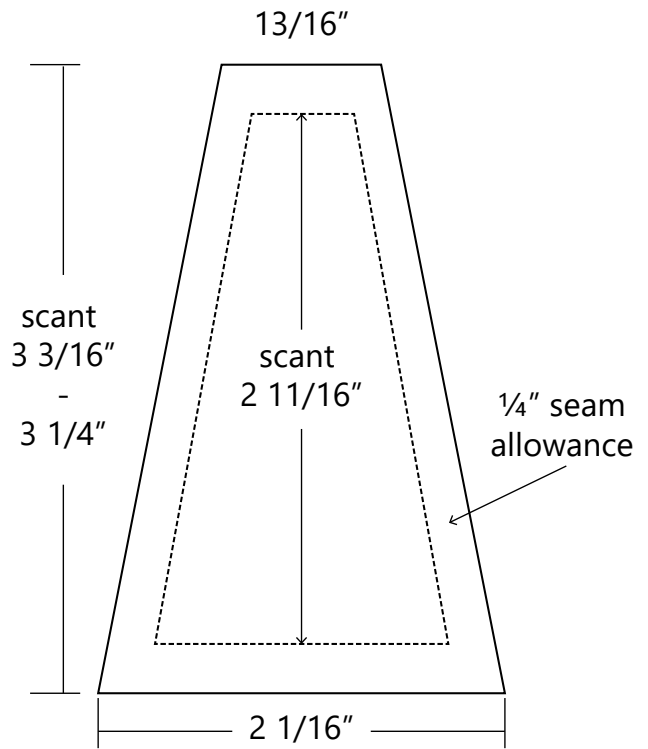

Side Dresden Fan Template
Cut (16) Fabrics I & K

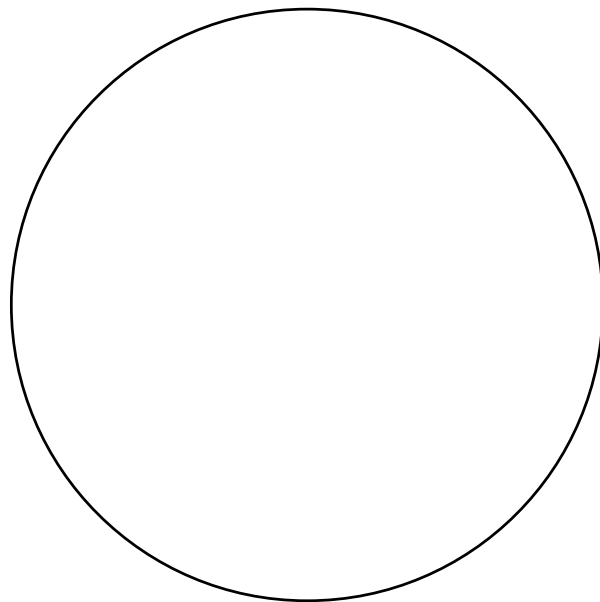

Also need template for 3" circle
Label: Cut (3) Fabric E

Color Placement Diagram

Pineapple Block

10 1/2" finished

11" with seam allowance

Logs = 3/4" wide/finished

